

V2FH-316-300 SERIES

CLASS 300, 2 PIECE DIRECT MOUNT
316 STAINLESS STEEL FLANGED BALL VALVE
DN15 - DN50

TECHNICAL DATA

Size Range:	DN15 - DN50 (½" - 2")
Pressure Rating:	ANSI-300
Pressure Test:	AP1598
Flange Connection:	ANSI-300
Features:	<ul style="list-style-type: none"> • SS316 body, cap & ball. • Full bore. • Solid ball. • Internal entry blow-out proof stem. • Lever operated. • Direct mounting pad ISO 5211. • Anti-static device, fire-safe design. • Flange pattern as required. • Fire-safe approved on request. • VEE port available on request.

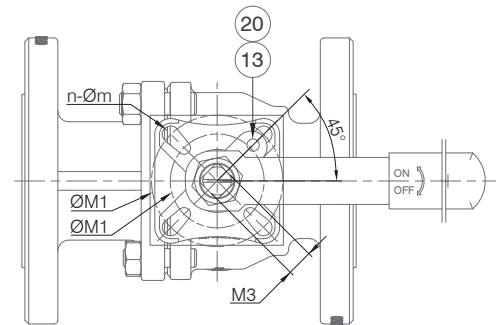
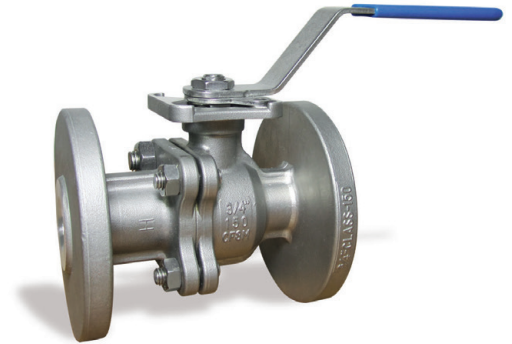

MATERIAL SPECIFICATIONS & PARTS LIST

NO.	DESCRIPTION	MATERIAL	NO.	DESCRIPTION	MATERIAL
1	Body	CF8M	12	Stem Nut	SS304
2	End Cap	CF8M	13	Stopper	SS304
3	Ball	CF8M	14	Handle	SS304
4	Seat	PTFE	15	Plastic Sleeve	Plastic
5	Joint Gasket	PTFE	16	Nut	SS304
6	Stem	SS316	17	Stud Bolt	SS304
7	Thrust Washer	PTFE	18	Nut	SS304
8	O-Ring	Viton	19	Stud Bolt	SS304
9	Stem Packing	PTFE	20	Stopper Pin	SS304
10	Stem Ring	SS304	21	Lock Washer	SS304
11	Belleville Washer	SS304			

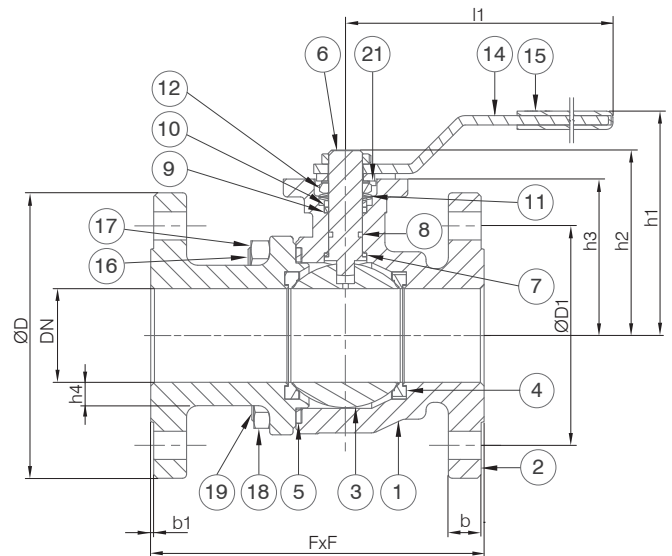

DIMENSIONS (MM)

V2FH-316-300 DN15 - DN50																
DN	NPS	Fx F	b	b1	ØD	ØD1	h1	h2	h3	h4	l1	ØM1	n-Øm	M3	Torque (N.m)	Weight (Kg)
15	½"	140	12.7	1.6	95	66.7	89	58	48	3.1	110	42	4-6	9	5	2.7
20	¾"	152	14.3	1.6	117	82.5	94	69	59	3.9	110	42/50	4-6/7	9	8	3.5
25	1"	165	15.9	1.6	125	89	95	72	63	4.9	136	42/50	4-6/7	11	11	5.4
40	1 ½"	190	19.1	1.6	156	114.5	111	92	78	4.9	203	50/70	4-7/9	14	21	8.5
50	2"	216	20.7	1.6	165	127	118	99	84	6.5	203	50/70	4-7/9	14	31	11.6

PRESSURE RATINGS

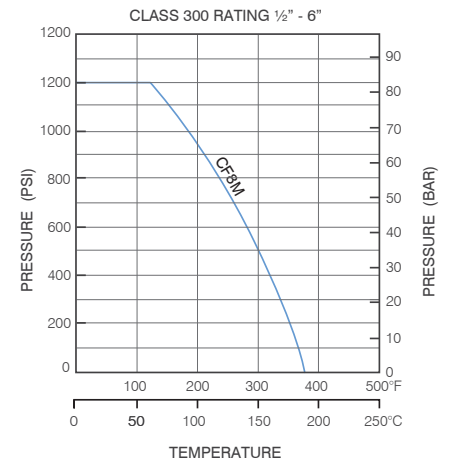

FACTORY ACCREDITED:



FIRE SAFETY
APPROVAL AP1607



6D-0645



No. WZ 1093
HH 1



NUMBER
0035

Designs, materials and specifications shown are subject to change without notice due to our continuing program of product development. V2FH-316-300_V1_DN15-DN50_20130618.

All content is protected by Copyright and is owned and/or licensed by AVFI Pty Ltd. Copyright © AVFI Pty Ltd.

AVFI Pty Ltd: 54 Enterprise Drive, Bundoora, Victoria, Australia 3083
T: 03 8467 0000 F: 03 8467 0099 E: avfi@avfi.com.au www.avfi.com.au