

3WAY-PPMH SERIES

3 WAY REDUCED BORE BSP LEVER OPERATED
316 STAINLESS STEEL BALL VALVE
DIRECT MOUNTING PAD



TECHNICAL DATA

Size Range:	DN8 - DN100 (1/4" - 4")
Pressure Rating:	1000PSI W.O.G
Pressure Test:	API598
Features:	<ul style="list-style-type: none"> • Direct mount pad to ISO5211. • L or T Port • Threaded BSP, NPT on request. • Quality Investment casting body & cap. • Internal entry blow-out proof stem. • Lever handle with locking device.

MATERIAL SPECIFICATIONS & PARTS LIST

NO.	DESCRIPTION	MATERIAL	NO.	DESCRIPTION	MATERIAL
1	Body	CF8M	10	Gland	SS304
2	Cap	CF8M	11	Belleville Washer	SS304
3	Ball	CF8M	12	Stem Nut	SS304
4	Seat	15% R-PTFE	13	Stop Washer	SS304
5	Stem	SS316	14	Handle Washer	SS304
6	Gasket	PTFE	15	Locking Device	SS304
7	Thrust Washer	PTFE	16	Handle	SS304
8	O-Ring	Viton	17	Handle Sleeve	Plastic
9	Packing	PTFE	18	Stop Pin	SS304

DIMENSIONS (MM)

3WAY-PPMH DN8 - DN100							ISO 5211 TOP FLANGE					
DN	NPS	Ød	FxF	h1	h3	l1	w1	FLANGE NO.	M3	Torque (N.m)	CV Factor (gallon/min)	Weight (Kg)
8	1/4"	9.5	75	66	8.5	130	57.5	F03/04	9	8.2	14.7	0.7
10	3/8"	11	75	66	8.5	130	57.5	F03/04	9	8.2	19.7	0.7
15	1/2"	12	75	66	8.5	130	57.5	F03/04	9	8.2	23.45	0.6
20	3/4"	15	85	72	11	161	65.5	F04/05	11	9.2	38.08	0.9
25	1"	20	100	77	12	161	79	F04/05	11	15.3	70.57	1.4
32	1 1/4"	25	122	92	13.5	203	97	F05/07	14	20.4	112.75	2.9
40	1 1/2"	32	131	96	13.5	203	106.5	F05/07	14	30.6	189.07	3.6
50	2"	40	158	107	13	203	129	F05/07	14	45.9	310.59	6.2
65	2 1/2"	49	178	135	18	254	145	F07/10	17	51	478.85	8.7
80	3"	60	202	147	17	254	167	F07/10	17	81.6	717.98	12.8
100	4"	75	246	160	20	310	203	F07/10	17	112.2	1154.36	20.6

FACTORY ACCREDITED:



FIRE SAFETY
APPROVAL AP1607



6D-0645



No. WZ 1093
HH 1



NUMBER
0035

Designs, materials and specifications shown are subject to change without notice due to our continuing program of product development.
3WAY-PP-MH_V2_20141023.

All content is protected by Copyright and is owned and/or licensed by AVFI Pty Ltd. Copyright © AVFI Pty Ltd.

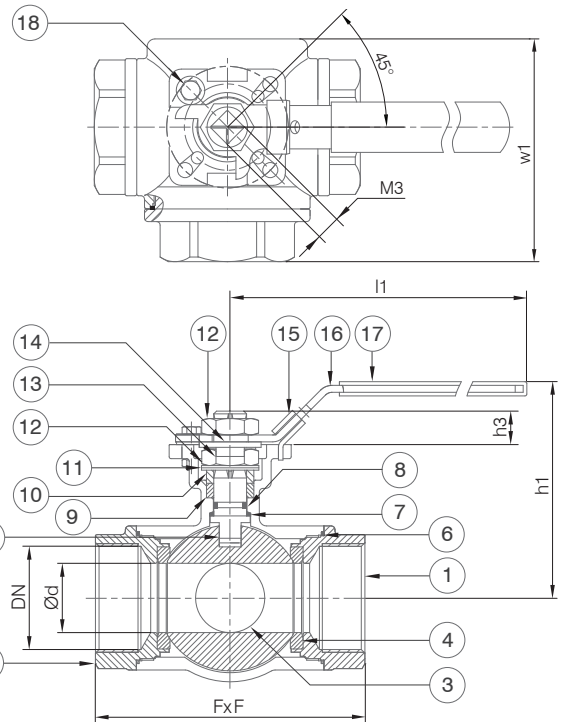

FIGURE 1. FLOW PATTERN

OPTIONS	1	2	3	4
L PORT				
T PORT				

PRESSURE RATINGS

