



AB10L



AB30W
(WaterMark Approved)

AB30L
(WaterMark Approved)



AB10W-PTFE-SS



AB10W-PTFE

FEATURES

- Designed and manufactured to AS4795.
- Phenolically backed replaceable liner.
- Rated to 1600kpa from 50mm up to 600mm and 1000kpa from 700mm up to 1200mm.
- Stainless steel fasteners.
- Bi-directional bubble-tight sealing, with no leakage under pressure.
- ISO top mounting flange for easy actuation.
- Gearbox fitted as standard on all sizes 350mm and above.

OPTIONS

- Gearboxes available for valves 300mm and below.
- Pneumatic and electric actuation.
- Limit switches and positioners.
- Extension fixed and non-fixed.
- Full 316 stainless steel lever and notch plate for valves 300mm and below.
- Wide selection of body & disc materials:
 - Cast Iron
 - Ductile Iron
 - Aluminium Bronze
 - Stainless Steel (SAF2205, SAF2507, 316L)
 - Other specialty materials on request
- Wide selection of seal materials:
 - EPDM
 - PTFE (Teflon) coated EPDM
 - NBR
 - FPM (Viton)
- Wide selection of coatings:
 - Rilsan (Nylon 11)
 - Plascoat (PPA)
 - Electro-less Nickle (ENC)
 - Rubber
 - Enamel
 - PTFE
- Connections to suit a wide range of flanging standards:
 - AS2129 T/ E
 - AS4087 CL16 (AS2129 T/D)
 - ANSI 150
 - EN 1092

ACCORDING TO

- ✓ AS4795
- ✓ API609
- ✓ MSS SP67
- ✓ ISO5752
- ✓ EN1092

APPROVED TO



* WaterMark approval for AB30W & AB30L only (Refer pages 3 & 6)

TECHNICAL DATA

Size Range:	DN50 - DN1200
Pressure Classes:	PN10, PN16, PN21 & PN25
Face to face:	According to AS4795
Top Flange:	According to ISO 5211
Temperature Range:	-20°C to +150°C (depending on seat material)
Leakage Tests:	According to AS4795
Coating:	Fusion Bonded Epoxy (For all cast and ductile iron bodied valves)

FACTORY ACCREDITED:



Designs, materials and specifications shown are subject to change without notice due to our continuing program of product development. AB Series_V10_20150729.

All content is protected by Copyright and is owned and/or licensed by AVFI Pty Ltd. Copyright© AVFI Pty Ltd.

AB SERIES

BUTTERFLY VALVES
DN50 - DN1200



DESCRIPTION

AVFI's AB Series Butterfly Valve with hard phenolic seat, pin or splined connection between disc and stem, both wafer and lug style. Suitable for most general purpose applications.

STEM CONFIGURATION

Square on sizes up to 300mm and round on sizes 350mm.

DOUBLE O-RING

Prevents leakage from stem.

CONNECTION BETWEEN DISC & SHAFT

Pin, spline or square connection are all available.

SEAT (LINER)

Phenolic backed, non-collapsible with good stretch resistance, easily replaceable.

TOP FLANGE

Top flange as per ISO 5211 standard for simple fitting of handle or actuator.

BUSHING

Stem bushing reduces valve torque and prevents stem corrosion. PTFE or bronze available.

SHAFT SEAL

Bonding of elastomer to phenolic backing ring protects against distortion. A common cause of shaft leakage.

DISC

Precision profile disc provides bubble-tight shut-off and assures minimum torque value and long seal life.

page 2

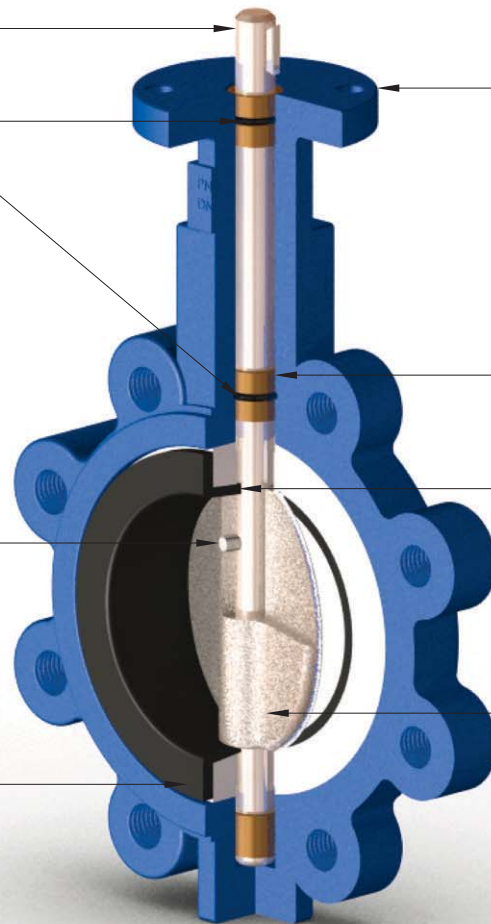

MATERIAL SPECIFICATIONS & PARTS LIST

NO.	DESCRIPTION	MATERIAL
1	Body	Ductile Iron (fusion bonded epoxy coated)
2	Bushing	PTFE
3	O-Ring	NBR
4	Stem	Stainless Steel
5	Disc	Stainless Steel 316
6	Seat	EPDM
7	Notch Plate & Fasteners	Stainless Steel

NOMINAL PRESSURE		PN16
Test:	Strength Test	24Bar
Pressure:	Sealing Test	17.6Bar
Max Working Temperature:		-25°C to +100°C
Suitable Media:		W.O.G etc

Note: PN21 & PN25, dimensions available on request.
For lever handle dimensions, refer to pg13.

Approved To:



DIMENSIONAL DRAWINGS

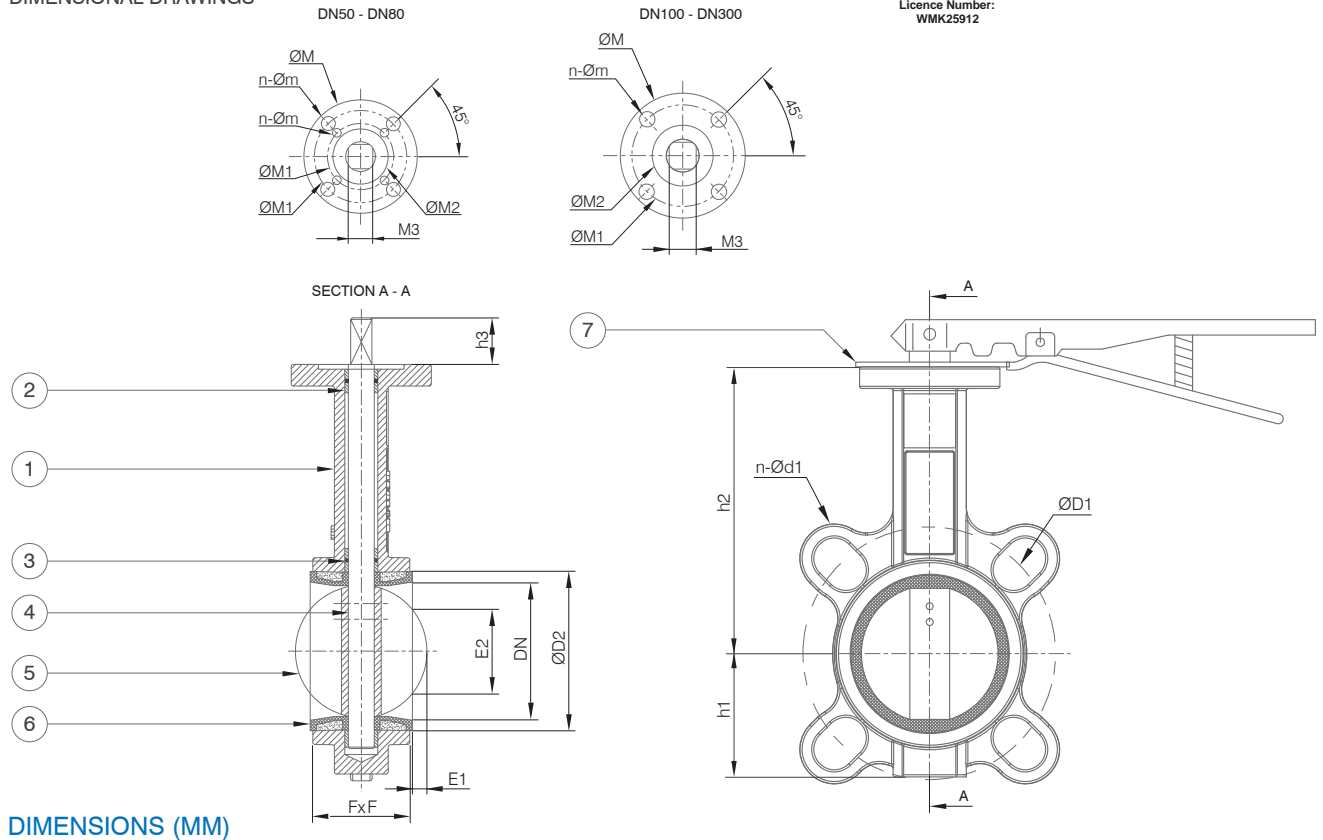

DIMENSIONS (MM)

WAFFER TYPE BFLY DN50 - DN300								AS2129 T/D AS2129 T/E		AS2129 T/D	AS2129 T/E	ANSI150		ISO 5211 TOP FLANGE						
DN	FxF	h1	h2	h3	E1	E2	ØD2	ØD1	n-Ød1	n-Ød1	ØD1	n-Ød1	FLANGE NO.	ØM	n-Øm	ØM1	ØM2	M3	Weight (kg)	
50	43	57	143	29	3.2	25.1	77	114	4-18	4-18	120.6	4-19	F05/F07	90	4-8/4-10	50/70	35.5	11x11	3.66	
65	46	68	155	29	7.6	41.4	89	127	4-18	4-18	139.7	4-19	F05/F07	90	4-8/4-10	50/70	35.5	11x11	4.28	
80	46	82	160	29	14.9	61.8	104	146	4-18	4-18	152.4	4-19	F05/F07	90	4-8/4-10	50/70	35.5	11x11	4.6	
100	52	100	181	29	25.1	89.1	135	178	4-18	8-18	190.5	8-19	F07	90	4-10	70	55.5	11x11	5.8	
125	56	112	194	29	32.6	108.7	159	210	8-18	8-18	215.9	8-22.4	F07	90	4-10	70	55.5	14x14	8	
150	56	126	202	29	48.9	144.6	189	235	8-18	8-22	241.3	8-22.4	F07	90	4-10	70	55.5	14x14	9.5	
200	60	162	240	35	70	192.5	239	292	8-18	8-22	298.4	8-22.4	F10	125	4-12	102	70.5	17x17	16	
250	68	193	272	35	90.3	240.5	293	356	8-22	12-22	361.9	12-25.4	F10	125	4-12	102	70.5	22x22	21	
300	78	236.5	318	35	111	290.8	345	406	12-22	12-26	431.8	12-25.4	F10	125	4-12	102	70.5	22x22	35	

AB10W PN10 OR PN16

WAFER TYPE BUTTERFLY VALVE
DN350 - DN600



MATERIAL SPECIFICATIONS & PARTS LIST

NO.	DESCRIPTION	MATERIAL
1	Body	Cast Iron (fusion bonded epoxy coated)
2	Bushing	PTFE
3	O-Ring	NBR
4	Pin	Stainless Steel
5	Stem	Stainless Steel
6	Disc	Stainless Steel 316
7	Seat	EPDM

NOMINAL PRESSURE		PN10	PN16
Test:	Strength Test	15Bar	24Bar
Pressure:	Sealing Test	11Bar	17.6Bar
Max Working Temperature:		-20°C to +100°C	
Suitable Media:		W.O.G etc	

Note: PN21 & PN25, dimensions available on request.
For gearbox dimensions, refer to pg14.

DIMENSIONAL DRAWINGS

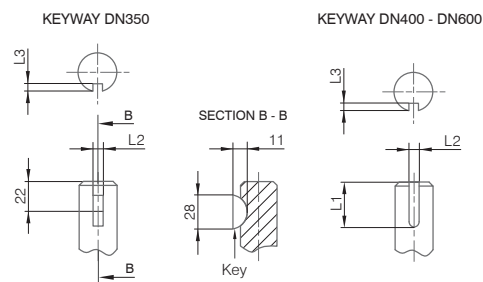
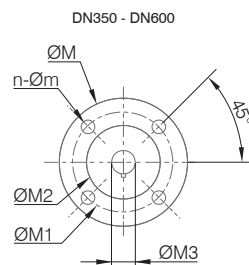

DN	KEYWAY		
	L1	L2	L3
350	22	8	8
400	45	10	5
450	45	10	5
500	56	10	5
600	58	16	6

SECTION A - A

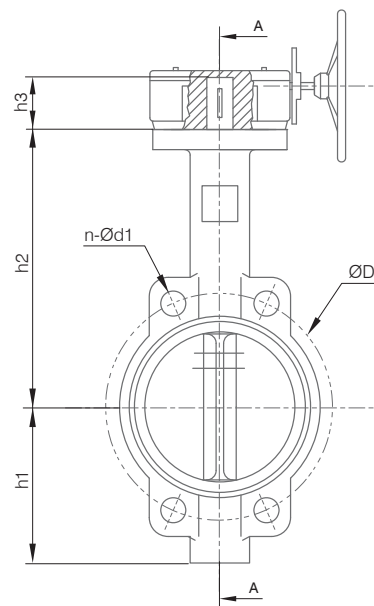
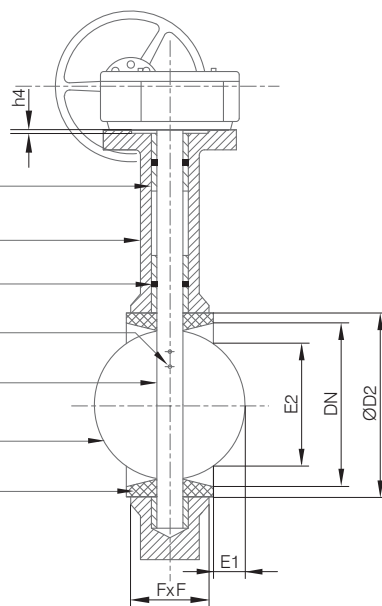

DIMENSIONS (MM)

WAFER TYPE BFLY DN350 - DN600								AS2129 T/D AS2129 T/E	AS2129 T/D	AS2129 T/E	ANSI150		ISO 5211 TOP FLANGE							
DN	FxF	h1	h2	h3	E1	E2	ØD2	ØD1	n-Ød1	n-Ød1	ØD1	n-Ød1	FLANGE NO.	ØM	n-Øm	ØM1	ØM2	ØM3	h4	Weight (kg)
350	78	267	368	45	126.9	323.7	376	470	12-26	12-26	476.2	12-28.4	F10	125	4-12	102	70.5	31.6	3.5	58
400	102	299	400	51.2	149.7	378.8	440	521	12-26	12-26	539.7	16-28.4	F14	175	4-18	140	100.5	33.15	4.5	107
450	114	318	422	51.2	166	427.3	491	584	12-26	16-26	577.8	16-31.8	F14	175	4-18	140	100.5	38	4.5	122
500	127	355	480	64.2	178.4	472.8	536	641	16-26	16-26	635	20-31.8	F14	175	4-18	140	100.5	41.15	4.5	160
600	154	444	562	70.2	218.4	571.9	655	756	16-30	16-33	749.3	20-35.1	F16	210	4-22	165	130.5	50.65	5.5	260

Designs, materials and specifications shown are subject to change without notice due to our continuing program of product development. AB Series_V10_20150729.

All content is protected by Copyright and is owned and/or licensed by AVFI Pty Ltd. Copyright© AVFI Pty Ltd.

MATERIAL SPECIFICATIONS & PARTS LIST

NO.	DESCRIPTION	MATERIAL
1	Body	Cast Iron (fusion bonded epoxy coated)
2	Bushing	PTFE
3	O-Ring	EPDM
4	Stem	Stainless Steel
5	Disc	Stainless Steel 316
6	Seat	EPDM
7	Pin	Stainless Steel

NOMINAL PRESSURE		PN10
Test:	Strength Test	15Bar
Pressure:	Sealing Test	11Bar
Max Working Temperature:	-20°C to +100°C	
Suitable Media:	W.O.G etc	

Note: PN16, PN21 & PN25 dimensions available on request.
For gearbox dimensions, refer to pg14.

DIMENSIONAL DRAWINGS

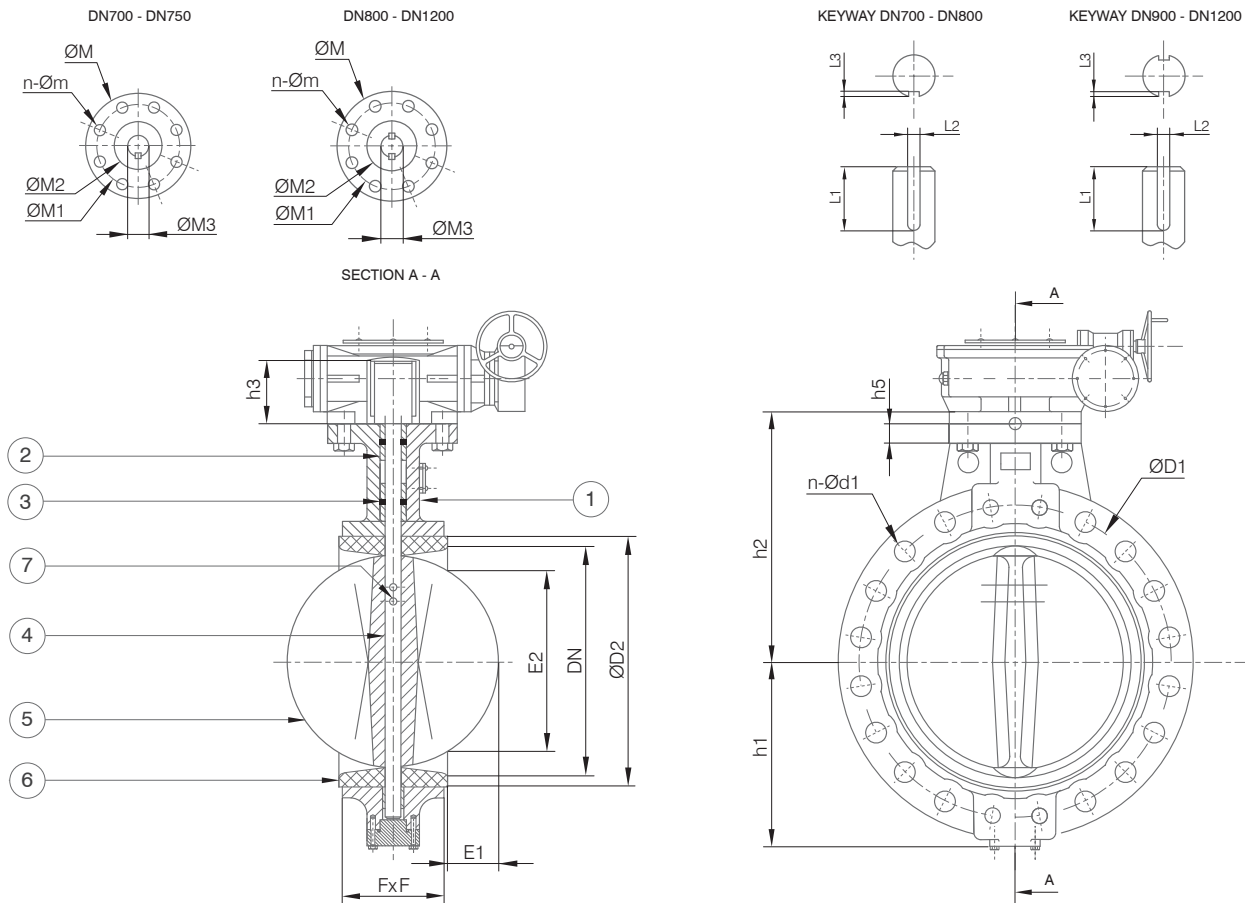

DIMENSIONS (MM)

WAFER TYPE BFLY DN700 - DN1200										AS2129 T/E		ISO 5211 TOP FLANGE						KEYWAY		
DN	FxF	h1	h2	h3	E1	E2	ØD2	ØD1	n-Ød1	FLANGE NO.	ØM	n-Øm	ØM1	ØM2	ØM3	h5	Weight (kg)	L1	L2	L3
700	165	505.1	623.9	66	265.5	679.3	745	845	20-33	F25	300	8-18	254	200.5	55	33	413	60	16	6
750	166	499	646	66	284.9	724	795	927	20-36	F25	300	8-18	254	200.5	55	33	425	60	16	6
800	190	576	672	66	299.5	769.7	850	984	20-36	F25	300	8-18	254	200.5	55	35	502	60	16	6
900	203	637	720	118	326.7	838.3	947	1092	24-36	F25	300	8-18	254	200.5	75	35	893	110	22	9
1000	216	701	800	142	370.1	937.8	1053	1175	24-39	F25	300	8-18	254	200.5	85	35	963	125	22	9
1200	254	844	940	160	436.3	1122.6	1265	1410	32-39	F30	350	8-22	298	230.5	105	35	1251	150	28	10

AB30L

WATERMARK APPROVED
TABLE E LUGGED TYPE BUTTERFLY VALVE
DN50 - DN300



MATERIAL SPECIFICATIONS & PARTS LIST

NO.	DESCRIPTION	MATERIAL
1	Body	Ductile Iron (fusion bonded epoxy coated)
2	Bushing	PTFE
3	O-Ring	NBR
4	Stem	Stainless Steel
5	Disc	Stainless Steel 316
6	Seat	EPDM
7	Notch Plate & Fasteners	Stainless Steel

NOMINAL PRESSURE	PN16	
Test:	Strength Test	24Bar
Pressure:	Sealing Test	17.6Bar
Max Working Temperature:	-20°C to +100°C	
Suitable Media:	W.O.G etc	

Note: PN21 & PN25 dimensions available on request.
For lever handle dimensions, refer to pg13.



DIMENSIONAL DRAWINGS

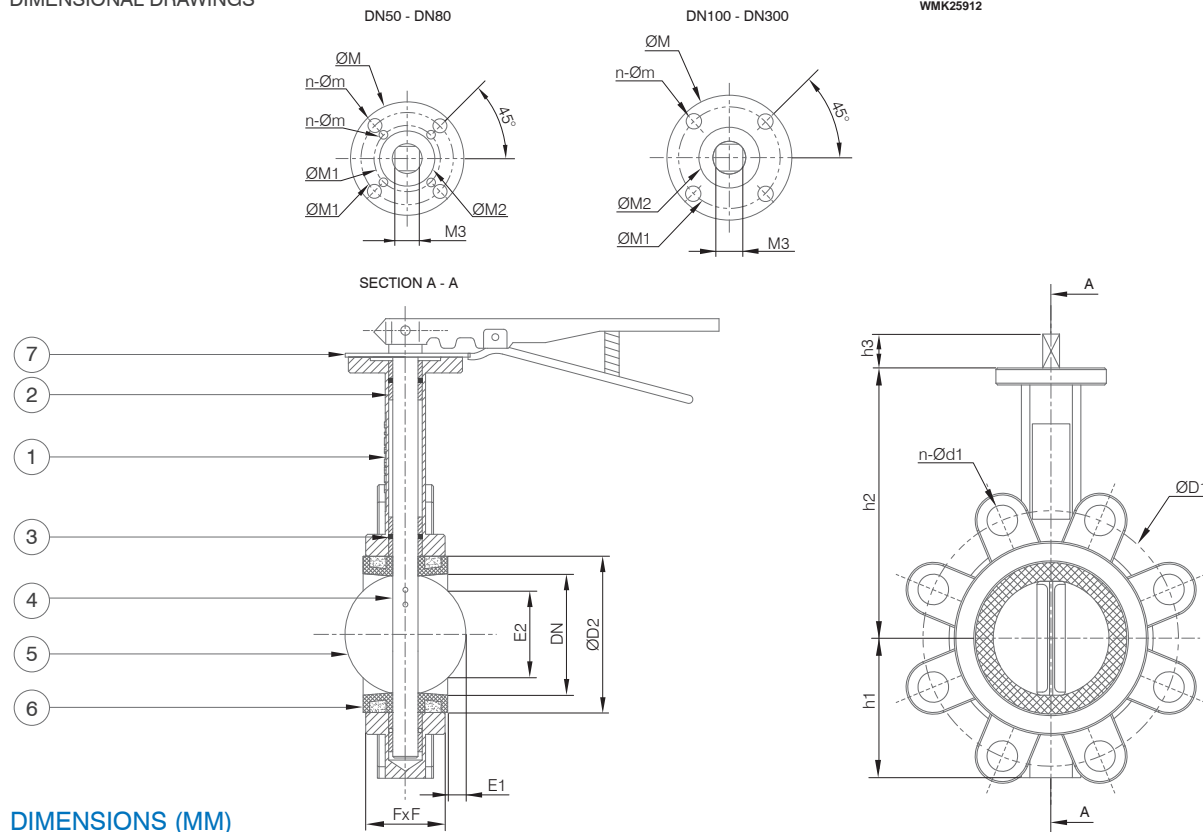

DIMENSIONS (MM)

LUGGED TYPE BFLY DN50 - DN300								AS2129 T/E		ISO 5211 TOP FLANGE						
DN	FxF	h1	h2	h3	E1	E2	ØD2	ØD1	n-Ød1	FLANGE NO.	ØM	n-Øm	ØM1	ØM2	M3	Weight (kg)
50	43	57	143	29	3.2	25.1	77	114	4-M16	F05/F07	90	4-8/4-10	50/70	35.5	11x11	4.5
65	46	68	155	29	7.6	41.4	89	127	4-M16	F05/F07	90	4-8/4-10	50/70	35.5	11x11	5
80	46	82	160	29	14.9	61.8	104	146	4-M16	F05/F07	90	4-8/4-10	50/70	35.5	11x11	6.2
100	52	100	181	29	25.1	89.1	135	178	8-M16	F07	90	4-10	70	55.5	11x11	9.2
125	56	112	194	29	32.6	108.7	159	210	8-M16	F07	90	4-10	70	55.5	14x14	11.6
150	56	126	202	29	48.9	144.6	189	235	8-M20	F07	90	4-10	70	55.5	14x14	13.2
200	60	162	240	35	70	192.5	239	292	8-M20	F10	125	4-12	102	70.5	17x17	21
250	68	193	272	35	90.3	240.5	293	356	12-M20	F10	125	4-12	102	70.5	22x22	31
300	78	236.5	318	35	111	290.8	345	406	12-M24	F10	125	4-12	102	70.5	22x22	46.4

Designs, materials and specifications shown are subject to change without notice due to our continuing program of product development. AB Series_V10_20150729.

All content is protected by Copyright and is owned and/or licensed by AVFI Pty Ltd. Copyright© AVFI Pty Ltd.

MATERIAL SPECIFICATIONS & PARTS LIST

NO.	DESCRIPTION	MATERIAL
1	Body	Cast Iron (fusion bonded epoxy coated)
2	Bushing	PTFE
3	O-Ring	NBR
4	Pin	Stainless Steel
5	Stem	Stainless Steel
6	Disc	Stainless Steel 316
7	Seat	EPDM

NOMINAL PRESSURE		PN10	PN16
Test:	Strength Test	15Bar	24Bar
Pressure:	Sealing Test	11Bar	17.6Bar
Max Working Temperature:		-20°C to +100°C	
Suitable Media:		W.O.G etc	

Note: PN21 & PN25 dimensions available on request.
For gearbox dimensions, refer to pg14.

DIMENSIONAL DRAWINGS

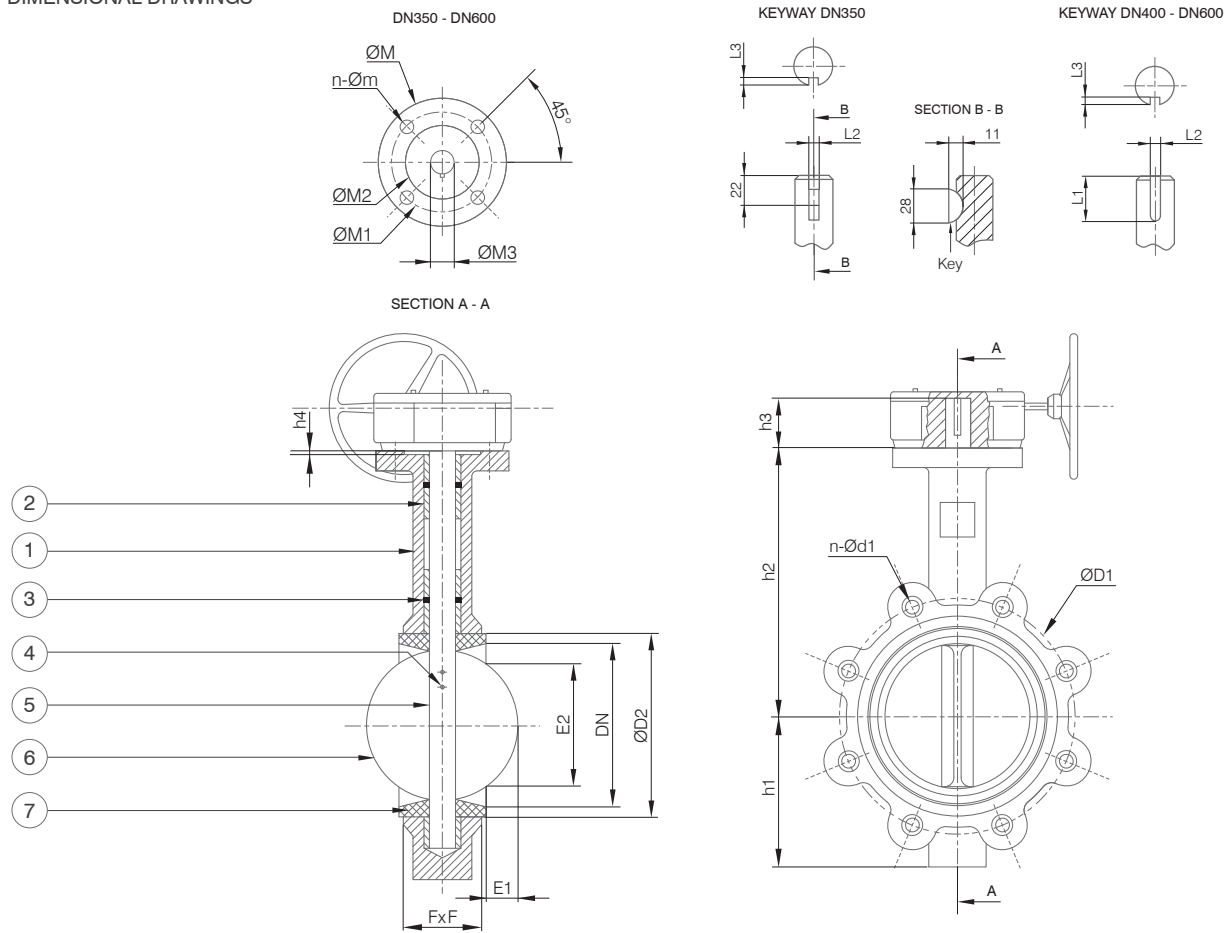

DIMENSIONS (MM)

LUGGED TYPE BFLY DN350 - DN600										AS2129 T/E		ISO 5211 TOP FLANGE						KEYWAY		
DN	FxF	h1	h2	h3	E1	E2	$\varnothing D2$	$\varnothing D1$	n- $\varnothing d1$	FLANGE NO.	$\varnothing M$	n- $\varnothing m$	$\varnothing M1$	$\varnothing M2$	$\varnothing M3$	h4	Weight (kg)	L1	L2	L3
350	78	267	368	45	126.9	323.7	376	470	12-M24	F10	125	4-12	102	70.5	31.6	3.5	81	22	8	8
400	102	299	400	51.2	149.7	378.8	440	521	12-M24	F14	175	4-18	140	100.5	33.15	4.5	140	45	10	5
450	114	318	422	51.2	166	427.3	491	584	16-M24	F14	175	4-18	140	100.5	38	4.5	176	45	10	5
500	127	348	480	64.2	178.4	472.8	536	641	16-M24	F14	175	4-18	140	100.5	41.15	4.5	226	56	10	5
600	154	444	562	70.2	218.4	571.9	655	756	16-M30	F16	210	4-22	165	130.5	50.65	5.5	336	58	16	6

AB30L - TD

AS4087 CL16 (TABLE D)
LUGGED TYPE BUTTERFLY VALVE
DN50 - DN300



MATERIAL SPECIFICATIONS & PARTS LIST

NO.	DESCRIPTION	MATERIAL
1	Body	Ductile Iron (fusion bonded epoxycoated)
2	Bushing	PTFE
3	O-Ring	NBR
4	Stem	Stainless Steel
5	Disc	Stainless Steel 316
6	Seat	EPDM
7	Notch Plate & Fasteners	Stainless Steel

NOMINAL PRESSURE		PN16
Test:	Strength Test	24Bar
Pressure:	Sealing Test	17.6Bar
Max Working Temperature:		-20°C to +100°C
Suitable Media:		W.O.G etc

Note: For lever handle dimensions, refer to pg13.

DIMENSIONAL DRAWINGS

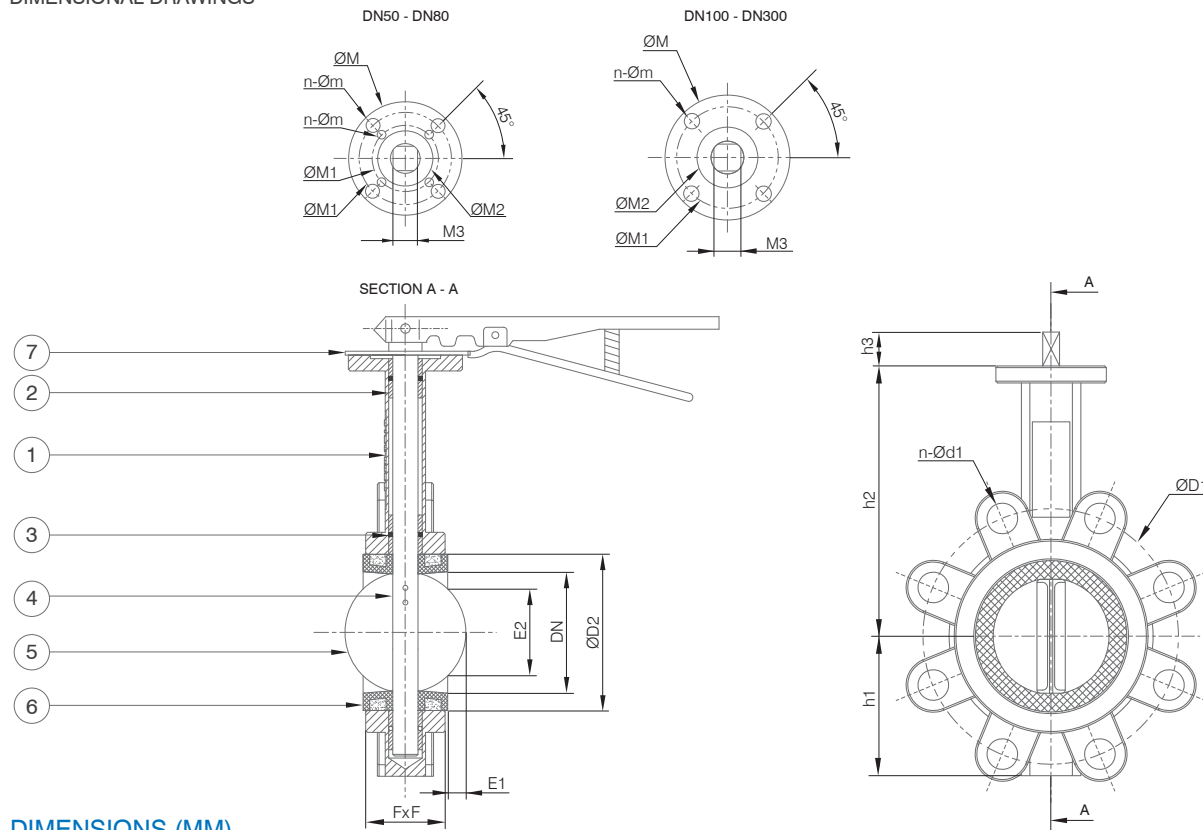

page 8

DIMENSIONS (MM)

LUGGED TYPE BFLY DN50 - DN300								AS4087 CL16		ISO 5211 TOP FLANGE						
DN	FxF	h1	h2	h3	E1	E2	ØD2	ØD1	n-Ød1	FLANGE NO.	ØM	n-Øm	ØM1	ØM2	M3	Weight (kg)
50	43	57	143	29	3.2	25.1	77	114	4-M16	F05/F07	90	4-8/4-10	50/70	35.5	11x11	4.5
65	46	68	155	29	7.6	41.4	89	127	4-M16	F05/F07	90	4-8/4-10	50/70	35.5	11x11	5
80	46	82	160	29	14.9	61.8	104	146	4-M16	F05/F07	90	4-8/4-10	50/70	35.5	11x11	6.2
100	52	100	181	29	25.1	89.1	135	178	4-M16	F07	90	4-10	70	55.5	11x11	9.2
125	56	112	194	29	32.6	108.7	159	210	8-M16	F07	90	4-10	70	55.5	14x14	11.6
150	56	126	202	29	48.9	144.6	189	235	8-M16	F07	90	4-10	70	55.5	14x14	13.2
200	60	162	240	35	70	192.5	239	292	8-M16	F07	125	4-12	102	70.5	17x17	21
250	68	193	272	35	90.3	240.5	293	356	8-M20	F07	125	4-12	102	70.5	22x22	31
300	78	236.5	318	35	111	290.8	345	406	12-M20	F07	125	4-12	102	70.5	22x22	46.4

Designs, materials and specifications shown are subject to change without notice due to our continuing program of product development. AB Series_V10_20150729.

All content is protected by Copyright and is owned and/or licensed by AVFI Pty Ltd. Copyright© AVFI Pty Ltd.

MATERIAL SPECIFICATIONS & PARTS LIST

NO.	DESCRIPTION	MATERIAL
1	Body	Cast Iron (fusion bonded epoxy coated)
2	Bushing	PTFE
3	O-Ring	NBR
4	Pin	Stainless Steel
5	Stem	Stainless Steel
6	Disc	Stainless Steel 316
7	Seat	EPDM

NOMINAL PRESSURE		PN10	PN16
Test:	Strength Test	15Bar	24Bar
Pressure:	Sealing Test	11Bar	17.6Bar
Max Working Temperature:		-20°C to +100°C	
Suitable Media:		W.O.G etc	

Note: For gearbox dimensions, refer to pg14.

DIMENSIONAL DRAWINGS

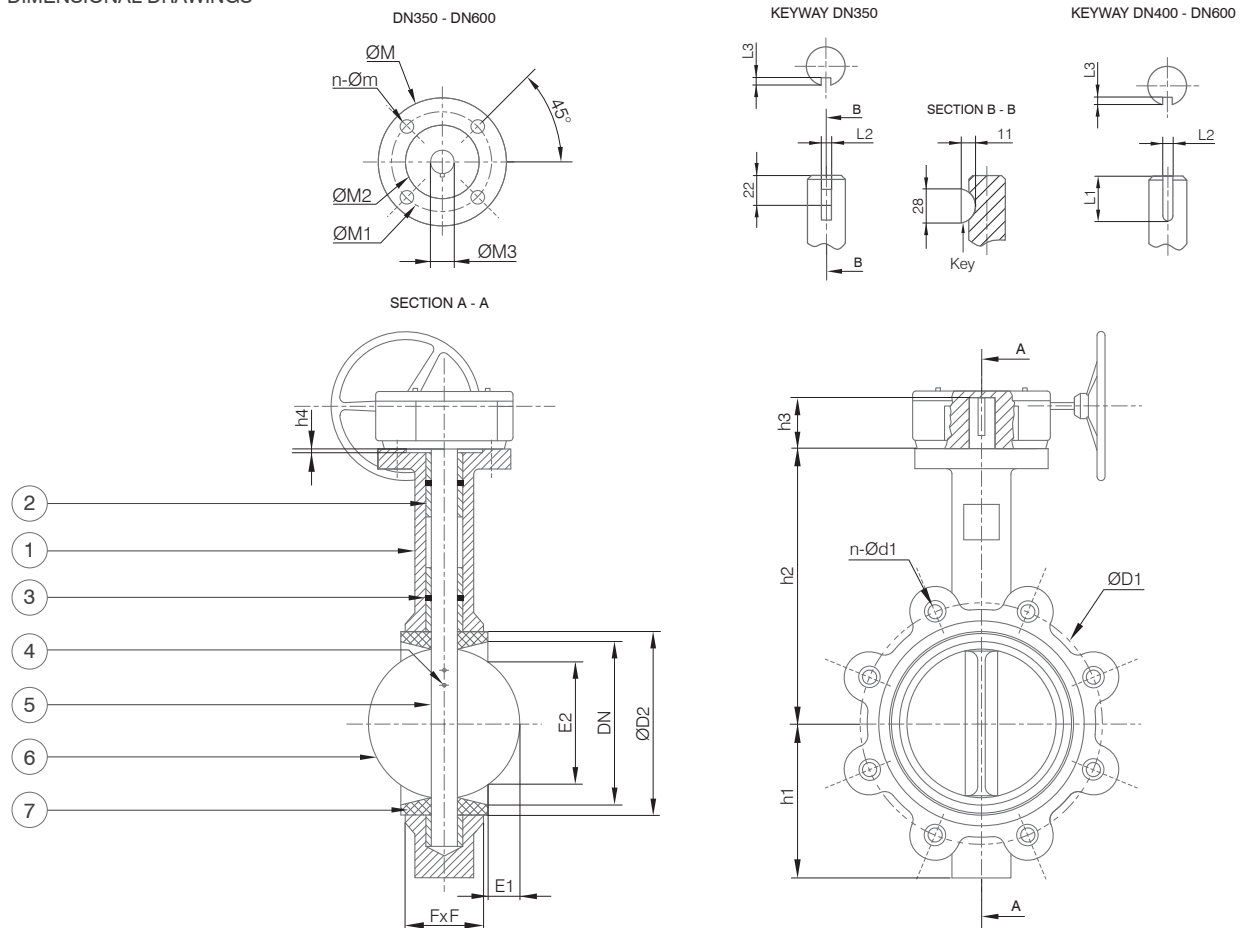

DIMENSIONS (MM)

LUGGED TYPE BFLY DN350 - DN600								AS4087 CL16		ISO 5211 TOP FLANGE							KEYWAY			
DN	FxF	h1	h2	h3	E1	E2	ØD2	ØD1	n-Ød1	FLANGE NO.	ØM	n-Øm	ØM1	ØM2	ØM3	h4	Weight (kg)	L1	L2	L3
350	78	267	368	45	126.9	323.7	376	470	12-M24	F10	125	4-12	102	70.5	31.6	3.5	81	22	8	8
400	102	299	400	51.2	149.7	378.8	440	521	12-M24	F14	175	4-18	140	100.5	33.15	4.5	140	45	10	5
450	114	318	422	51.2	166	427.3	491	584	12-M24	F14	175	4-18	140	100.5	38	4.5	176	45	10	5
500	127	348	480	64.2	178.4	472.8	536	641	16-M24	F14	175	4-18	140	100.5	41.15	4.5	226	56	10	5
600	154	444	562	70.2	218.4	571.9	655	756	16-M27	F16	210	4-22	165	130.5	50.65	5.5	336	58	16	6

Designs, materials and specifications shown are subject to change without notice due to our continuing program of product development. AB Series_V10_20150729.

All content is protected by Copyright and is owned and/or licensed by AVFI Pty Ltd. Copyright© AVFI Pty Ltd.

AB10W - PTFE

DUCTILE IRON WITH PTFE COATED DISC & SEAT
 WAFER TYPE BUTTERFLY VALVE
 DN50 - DN300



MATERIAL SPECIFICATIONS & PARTS LIST

NO.	DESCRIPTION	MATERIAL
1	Body	Ductile Iron (fusion bonded epoxy coated)
2	Bushing	PTFE
3	O-Ring	EPDM
4	Stem	Stainless Steel 316
5	Disc	SS316 coated by PTFE
6	Seat	EPDM coated by PTFE
7	Notch Plate & Fasteners	Stainless Steel

NOMINAL PRESSURE		PN10
Test:	Strength Test	15Bar
Pressure:	Sealing Test	11Bar
Max Working Temperature:		-20°C to +120°C
Suitable Media:		W.O.G etc

Note: Also available in 350mm-600mm.
 For lever handle dimensions, refer to pg13.

DIMENSIONAL DRAWINGS

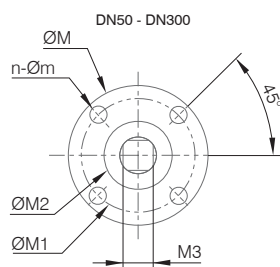

SECTION A - A

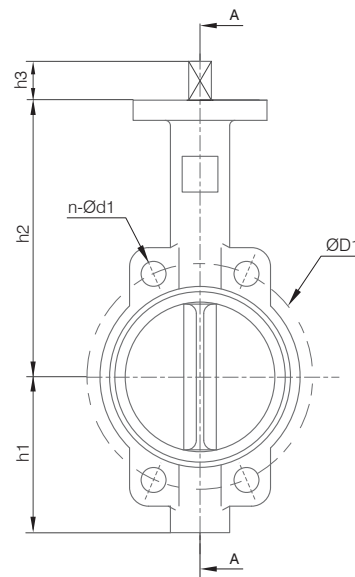
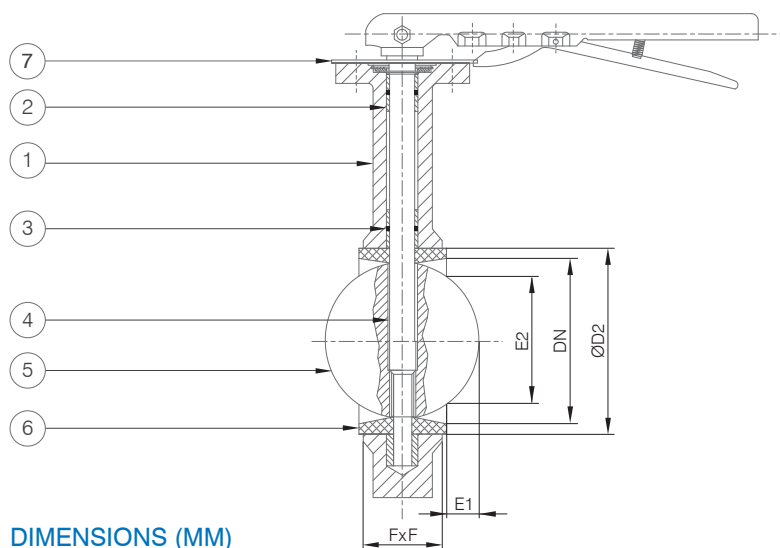

DIMENSIONS (MM)

PTFE WAFER TYPE BFLY DN50 - DN300							AS2129 T/D AS2129 T/E	AS2129 T/D	AS2129 T/E	ANSI150		ISO 5211 TOP FLANGE							
DN	FxF	h1	h2	h3	E1	E2	ØD2	ØD1	n-Ød1	n-Ød1	ØD1	n-Ød1	FLANGE NO.	ØM	n-Øm	ØM1	ØM2	M3	Weight (kg)
50	43	80	161	29	3.2	25.1	77	114	4-18	4-18	120.6	4-19	F07	90	4-10	70	35.5	11x11	3.66
65	46	89	175	29	7.6	41.4	89	127	4-18	4-18	139.7	4-19	F07	90	4-10	70	35.5	11x11	4.28
80	46	95	181	29	14.9	61.8	104	146	4-18	4-18	152.4	4-19	F07	90	4-10	70	35.5	11x11	4.6
100	52	114	200	29	25.1	89.1	135	178	4-18	8-18	190.5	8-19	F07	90	4-10	70	55.5	11x11	5.8
125	56	127	213	29	32.6	108.7	159	210	8-18	8-18	215.9	8-22.4	F07	90	4-10	70	55.5	14x14	8
150	56	139	226	29	48.9	144.6	189	235	8-18	8-22	241.3	8-22.4	F07	90	4-10	70	55.5	14x14	9.5
200	60	175	260	35	70	192.5	239	292	8-18	8-22	298.4	8-22.4	F10	125	4-12	102	70.5	17x17	16
250	68	203	292	35	90.3	240.5	293	356	8-22	12-22	361.9	12-25.4	F10	125	4-12	102	70.5	22x22	21
300	78	242	337	35	111	290.8	345	406	12-22	12-26	431.8	12-25.4	F10	125	4-12	102	70.5	22x22	35

Designs, materials and specifications shown are subject to change without notice due to our continuing program of product development. AB Series_V10_20150729.

All content is protected by Copyright and is owned and/or licensed by AVFI Pty Ltd. Copyright© AVFI Pty Ltd.

MATERIAL SPECIFICATIONS & PARTS LIST

NO.	DESCRIPTION	MATERIAL
1	Body	Ductile Iron (fusion bonded epoxy coated)
2	Bushing	PTFE
3	O-Ring	EPDM
4	Stem	Stainless Steel 316
5	Disc	SS316 coated by PTFE
6	Seat	EPDM coated by PTFE
7	Notch Plate & Fasteners	Stainless Steel

NOMINAL PRESSURE		PN10
Test:	Strength Test	15Bar
Pressure:	Sealing Test	11Bar
Max Working Temperature:		-20°C to +120°C
Suitable Media:		W.O.G etc

Note: Also available in 350mm-600mm.
For lever handle dimensions, refer to pg13.

DIMENSIONAL DRAWINGS

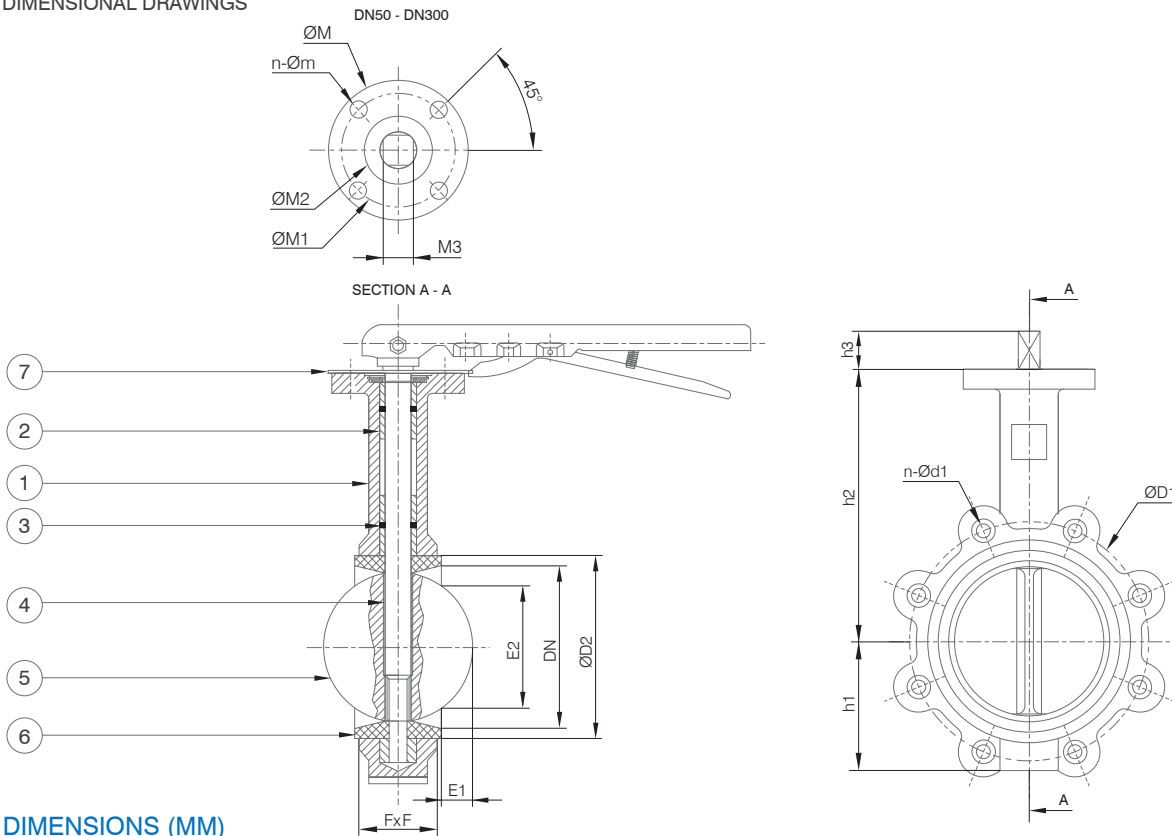

DIMENSIONS (MM)

PTFE LUGGED TYPE BFLY DN50 - DN300									AS2129 T/E		ISO 5211 TOP FLANGE					
DN	FxF	h1	h2	h3	E1	E2	ØD2	ØD1	n-Ød1	FLANGE NO.	ØM	n-Øm	ØM1	ØM2	M3	Weight (kg)
50	43	80	161	29	3.2	25.1	77	114	4-M16	F07	90	4-10	70	35.5	11x11	4.5
65	46	89	175	29	7.6	41.4	89	127	4-M16	F07	90	4-10	70	35.5	11x11	5
80	46	95	181	29	14.9	61.8	104	146	4-M16	F07	90	4-10	70	35.5	11x11	6.2
100	52	114	200	29	25.1	89.1	135	178	8-M16	F07	90	4-10	70	55.5	11x11	9.2
125	56	127	213	29	32.6	108.7	159	210	8-M16	F07	90	4-10	70	55.5	14x14	11.6
150	56	139	226	29	48.9	144.6	189	235	8-M20	F07	90	4-10	70	55.5	14x14	13.2
200	60	175	260	35	70	192.5	239	292	8-M20	F10	125	4-12	102	70.5	17x17	21
250	68	203	292	35	90.3	240.5	293	356	12-M20	F10	125	4-12	102	70.5	22x22	31
300	78	242	337	35	111	290.8	345	406	12-M24	F10	125	4-12	102	70.5	22x22	46.4

Designs, materials and specifications shown are subject to change without notice due to our continuing program of product development.
AB Series_V10_20150729.

All content is protected by Copyright and is owned and/or licensed by AVFI Pty Ltd. Copyright© AVFI Pty Ltd.

AB10W - PTFE - SS

STAINLESS STEEL WITH PTFE COATED DISC & SEAT
 WAFER TYPE BUTTERFLY VALVE
 DN50 - DN300



MATERIAL SPECIFICATIONS & PARTS LIST

NO.	DESCRIPTION	MATERIAL
1	Body	Stainless Steel 316
2	Bushing	PTFE
3	O-Ring	EPDM
4	Stem	Stainless Steel 316
5	Disc	SS316 coated by PTFE (Teflon)
6	Seat	EPDM coated by PTFE
7	Notch Plate & Fasteners	Stainless Steel

NOMINAL PRESSURE	PN10	
Test:	Strength Test	15Bar
Pressure:	Sealing Test	11Bar
Max Working Temperature:	-20°C to +120°C	
Suitable Media:	W.O.G etc	

Note: For lever handle dimensions, refer to pg13.

DIMENSIONAL DRAWINGS

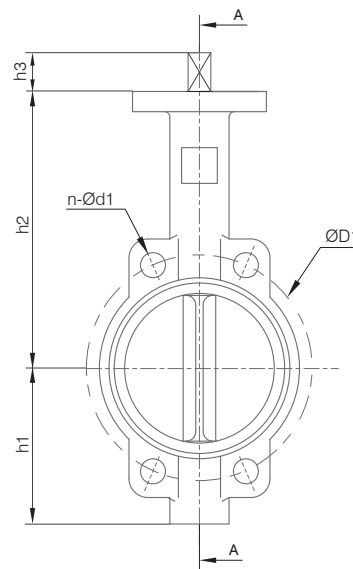
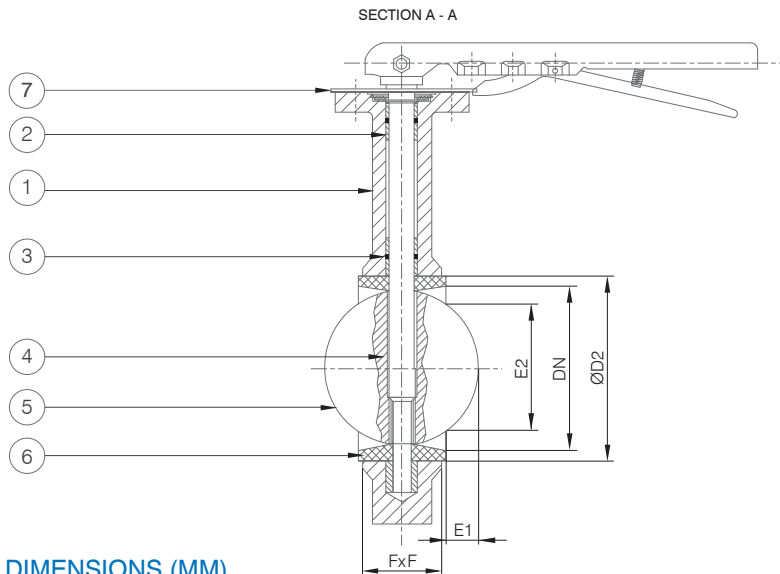
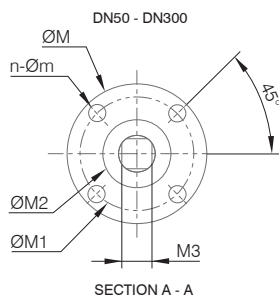

DIMENSIONS (MM)

PTFE-SS WAFLER TYPE BFLY PN50 - PN300							AS2129 T/D AS2129 T/E	AS2129 T/D	AS2129 T/E	ANSI150		ISO 5211 TOP FLANGE							
DN	Fx F	h1	h2	h3	E1	E2	ØD2	ØD1	n-Ød1	n-Ød1	ØD1	n-Ød1	FLANGE NO.	ØM	n-Øm	ØM1	ØM2	M3	Weight (kg)
50	43	80	161	29	3.2	25.1	77	114	4-18	4-18	120.6	4-19	F07	90	4-10	70	35.5	11x11	3.66
65	46	89	175	29	7.6	41.4	89	127	4-18	4-18	139.7	4-19	F07	90	4-10	70	35.5	11x11	4.28
80	46	95	181	29	14.9	61.8	104	146	4-18	4-18	152.4	4-19	F07	90	4-10	70	35.5	11x11	4.6
100	52	114	200	29	25.1	89.1	135	178	4-18	8-18	190.5	8-19	F07	90	4-10	70	55.5	11x11	5.8
125	56	127	213	29	32.6	108.7	159	210	8-18	8-18	215.9	8-22.4	F07	90	4-10	70	55.5	14x14	8
150	56	139	226	29	48.9	144.6	189	235	8-18	8-22	241.3	8-22.4	F07	90	4-10	70	55.5	14x14	9.5
200	60	175	260	35	70	192.5	239	292	8-18	8-22	298.4	8-22.4	F10	125	4-12	102	70.5	17x17	16
250	68	203	292	35	90.3	240.5	293	356	8-22	12-22	361.9	12-25.4	F10	125	4-12	102	70.5	22x22	21
300	78	242	337	35	111	290.8	345	406	12-22	12-26	431.8	12-25.4	F10	125	4-12	102	70.5	22x22	35

Designs, materials and specifications shown are subject to change without notice due to our continuing program of product development. AB Series_V10_20150729.

All content is protected by Copyright and is owned and/or licensed by AVFI Pty Ltd. Copyright © AVFI Pty Ltd.

DIMENSIONAL DRAWINGS

Figure 1. Lever handle

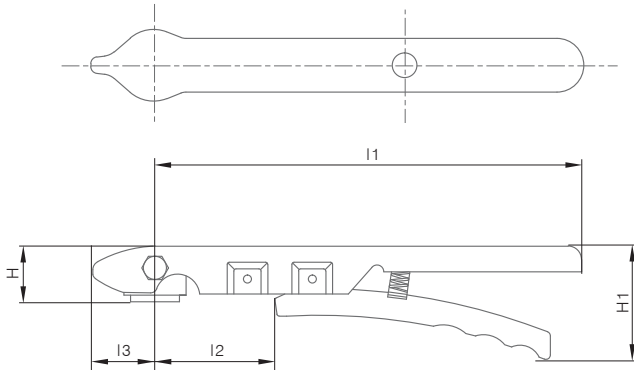

Note: Also available in stainless steel.

Figure 2. Notch plate

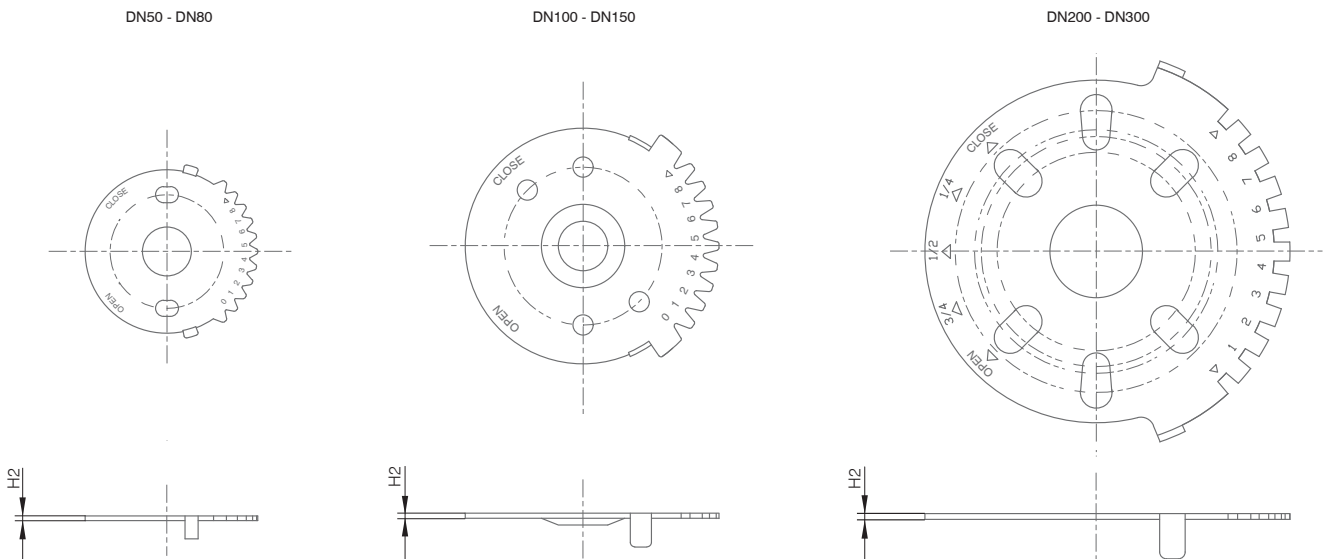

DIMENSIONS (MM)

DN	LEVER HANDLE					NOTCH PLATE	
	H	H1	I1	I2	I3	FLANGE NO.	H2
40-80	29	55.5	192	37	26.5	F05	2
100-150	29	46	259	54	24	F07	2.5
200-250	33	78	350	81	29	F10	2.5
300	32	73	375	81	25	F10	2.5

DIMENSIONAL DRAWINGS

DN50 - DN80
(AB30 SERIES)

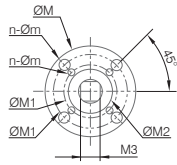

DN100 - DN300
(AB30 SERIES)
DN50 - DN300
(AB10 SERIES)

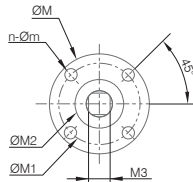

DN350 - DN600

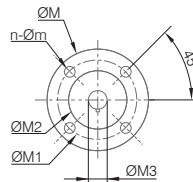

DN700 & DN750

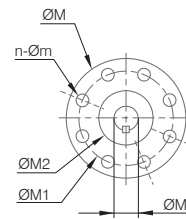

DN800 - DN1200

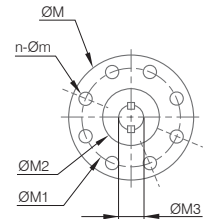

GEARBOX
DN50 - DN450

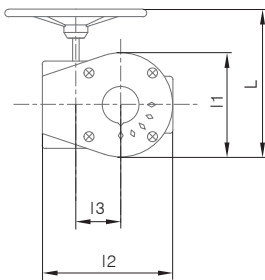

KEYWAY
DN350

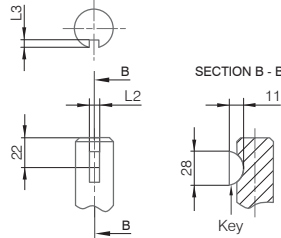

GEARBOX
DN500 - DN1200

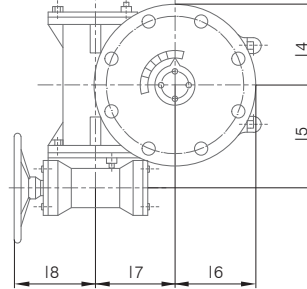

KEYWAY
DN700 & DN800

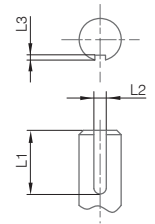

KEYWAY
DN400 - DN600

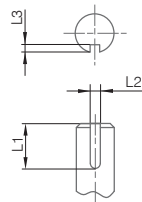

KEYWAY
DN900 - DN1200

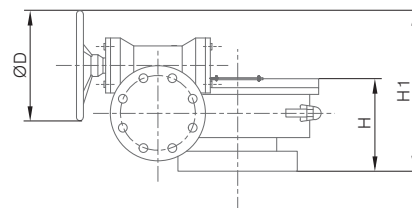
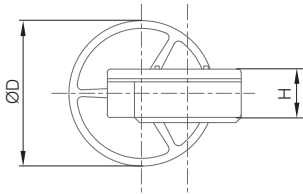
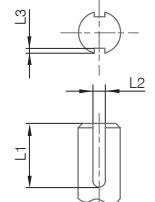

page 14

DIMENSIONS (MM)

MODEL	GEARBOX DN50 - DN1200							ISO 5211 TOP FLANGE							KEYWAY							
	DN	H	L	I1	I2	I3		Max. GB Torque (N.m)	Drive Ratio	Turns	Weights (Kg)	ØD	ØM	ØM1	ØM2	M3	ØM3	n-Øm	L1	L2	L3	
3DE-15	50	65	205	106	127	45		150	24:1	6	3.65	146	92	50/70	35.5	11x11	-	4-8/4-10	-	-	-	
3DE-15	65	65	205	106	127	45		150	24:1	6	3.65	146	92	50/70	35.5	11x11	-	4-8/4-10	-	-	-	
3DE-15	80	65	205	106	127	45		150	24:1	6	3.65	146	92	50/70	35.5	11x11	-	4-8/4-10	-	-	-	
3DE-15	100	65	205	106	127	45		150	24:1	6	3.65	146	92	70	55.5	11x11	-	4-10	-	-	-	
3DE-15	125	65	205	106	127	45		150	24:1	6	3.65	146	92	70	55.5	14x14	-	4-10	-	-	-	
3DE-15	150	65	205	106	127	45		150	24:1	6	3.65	146	92	70	55.5	14x14	-	4-10	-	-	-	
3DE-50	200	69	295	145	170	63		500	32:1	8	5.82	287	125	102	70.5	17x17	-	4-12	-	-	-	
3DE-50	250	69	295	145	170	63		500	32:1	8	5.82	287	125	102	70.5	22x22	-	4-12	-	-	-	
3DE-120	300	71	291	156	190	80		1200	50:1	12.5	5.82	287	125	102	70.5	22x22	-	4-12	-	-	-	
3DE-120	350	71	291	156	190	80		1200	50:1	12.5	5.82	287	125	102	70.5	-	31.6	4-12	22	8	8	
3DE-180	400	97	291	249	278	118		1800	80:1	20	20.15	385	175	140	100.5	-	33.2	4-18	45	10	5	
3DE-180	450	97	291	249	278	118		1800	80:1	20	20.15	385	175	140	100.5	-	38	4-18	45	10	5	
MODEL	DN	H	H1	I1	I2	I3	I4	I5	Max. GB Torque (N.m)	Drive Ratio	Turns	Weights (Kg)	ØD	ØM	ØM1	ØM2	M3	ØM3	n-Øm	L1	L2	L3
3D-30/250	500	125	271	107	168	107	100	156	2500	640:1	160	37	385	175	140	100.5	-	41.2	4-18	56	10	5
3D-30/400	600	136	330	131	193	131	125	160	4000	640:1	160	47	385	210	165	130.5	-	50.7	4-22	58	16	6
3D-60/800	700	158	373	173	245	173	162	197	8000	704:1	176	84	425	300	254	200.5	-	55	8-18	60	16	6
3D-60/800	750	158	373	173	245	173	162	197	8000	704:1	176	84	425	300	254	200.5	-	55	8-18	60	16	6
3D-60/800	800	158	373	173	245	173	162	197	8000	704:1	176	84	425	300	254	200.5	-	55	8-18	60	16	6
3D-120/1500	900	185	409	201	279	201	196	203	15000	748:1	187	110	425	300	254	200.5	-	75	8-18	110	22	9
3D-120/1500	1000	185	409	201	279	201	196	203	15000	748:1	187	145	425	300	254	200.5	-	85	8-18	125	22	9
3D-120/2500	1200	216	423	255	311	185	240	203	25000	850:1	212.5	205	425	350	298	230.5	-	105	8-22	150	28	10

Designs, materials and specifications shown are subject to change without notice due to our continuing program of product development. AB Series_V10_20150729.

All content is protected by Copyright and is owned and/or licensed by AVFI Pty Ltd. Copyright © AVFI Pty Ltd.

TORQUE VALUE AT PRESSURE CONDITION

VALVE SIZE (DN)		CLOSE-OFF TORQUE	
mm	inch	PN10	PN16
50	2"	11	15
65	2.5"	16	21
80	3"	21	30
100	4"	39	55
125	5"	56	79
150	6"	94	132
200	8"	135	197
250	10"	284	335
300	12"	440	520
350	14"	572	676
400	16"	648	843
450	18"	989	1286
500	20"	1237	1608
600	24"	2472	3214
700	28"	3370	5512
750	30"	3370	5512
800	32"	3370	5512
900	36"	4888	6834
1000	40"	5516	7722
1200	48"	7478	9722

Note: All torque value in left chart were derived from the actual test data using water at 20°C. For torque used in other media, please contact AVFI directly. Torques shown do not include safety factor.

For actuator selection, AVFI recommends:

- For EPDM, NBR, VITON and HYPOLEN seat, these valves be multiplied by 1.35 to 1.5 for single valve applications.
- For PTFE seat, multiply the above numbers by 2.

Kindly note under certain conditions, hydrodynamic torque can meet or exceed seating and unseating torques.

FLOWRATE

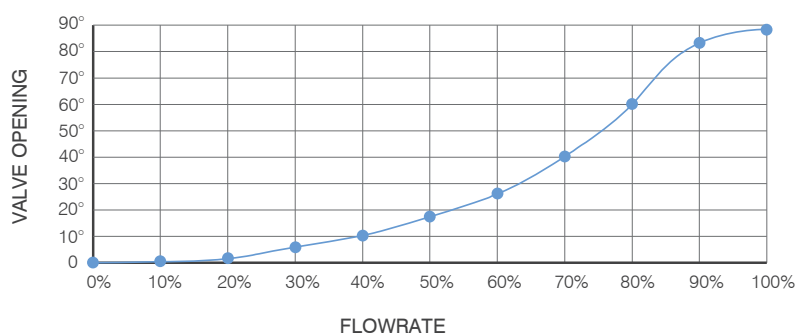

CV VALUES FOR AB SERIES

VALVE SIZE (DN)		CV VALUE								
mm	inch	10°	20°	30°	40°	50°	60°	70°	80°	90°
40	1 1/2	0.06	3	7	14	25	36	51	70	76
50	2	0.1	5	12	24	45	64	90	125	135
65	2 1/2	0.2	8	20	37	65	98	144	204	220
80	3	0.3	12	22	39	70	116	183	275	302
100	4	0.5	17	36	78	139	230	364	546	600
125	5	0.8	29	61	133	237	392	620	930	1022
150	6	2	45	95	205	366	605	958	1437	1579
200	8	3	89	188	408	727	1202	1903	2854	3136
250	10	4	151	320	694	1237	2047	3240	4859	5340
300	12	5	234	495	1072	1911	3162	5005	7507	8250
350	14	6	338	715	1549	2761	4568	7230	10844	11917
400	16	8	464	983	2130	3797	6282	9942	14913	16388
450	18	11	615	1302	2822	5028	8320	13168	19752	21705
500	20	14	791	1674	3628	6465	10698	16931	25396	27908
550	22	17	965	2042	4426	7887	13052	20655	30983	34048
600	24	22	1222	2587	5605	9989	16528	26157	39236	43116
650	26	26	1434	3036	6578	11723	19397	29263	46047	50600
700	28	30	1663	3522	7630	12599	20036	30482	46899	58696
750	30	35	1912	4050	8142	13152	20411	31226	47562	63328
800	32	45	2387	4791	8736	13788	20613	31395	48117	68250
850	34	51	2697	5414	9872	15580	23293	35476	54372	77123
900	36	60	3021	6063	11055	17449	26086	39731	60895	86375
1000	40	84	4183	8395	15307	24159	36166	55084	84425	119750
1050	42	350	4095	9040	17108	27150	43640	70500	106890	117500
1200	48	455	5365	11840	22400	30600	51200	92300	140000	154000