

V3-WC

3-PC WAFER DISC CHECK VALVE INVESTMENT CASTING

SIZE:DN15~DN100

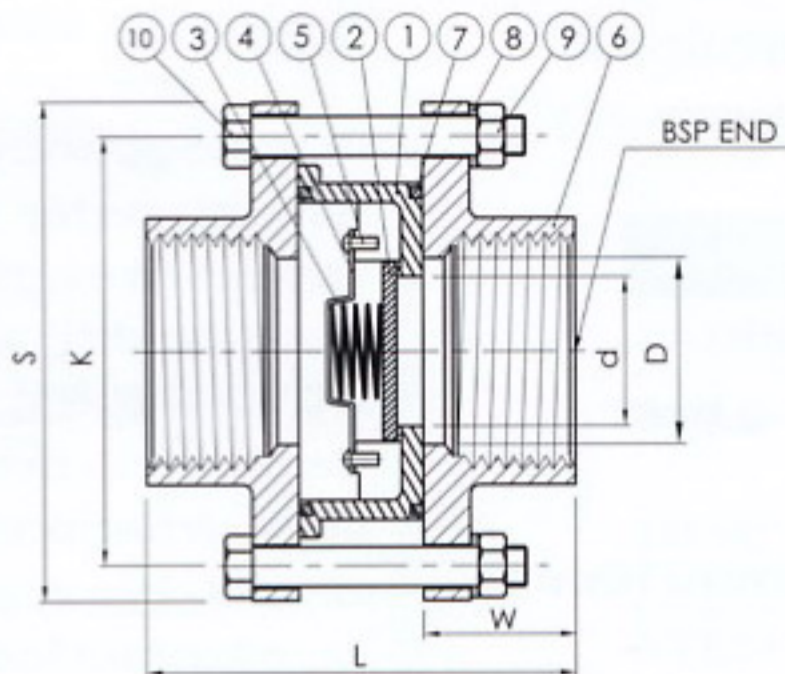

ITEM	PART	V3-WC MATERIAL	Q.TY
1	VT-WC BODY	ASTM-A351-CF8M	1
2	DISC	ASTM-A351-CF8M	1
3	SPRING	AISI 316	1
4	SPRING CAP	ASTM-A351-CF8M	1
5	SCREW	AISI 304	4
6	CAP	ASTM-A351-CF8M	2
7	JOINT GASKET	PTFE	2
8	SPRING WASHER	AISI 304	4
9	HEX NUT	AISI 304	4
10	BOLT	AISI 304	4

UNIT:MM

DN	SIZE	D	d	L	W	K	S	KGS
15	1/2	15	15	67.5	25.4	55	71	0.65
20	3/4	20	15	67.5	25.4	55	71	0.57
25	1"	25.4	20	75	27.8	63.5	80	0.77
32	1-1/4	32	25	82.5	30	77	95.5	1.19
40	1-1/2	38	30	98	35.3	87	106	1.64
50	2"	50.8	38	109	38.5	109	128	2.31
65	2-1/2	65	62.5	140	47	136	163	5.06
80	3"	80	77	154	52.5	164	193	7.83
100	4"	100	96	195	68	206	241	15.74

VT-WC

1-PC WAFER DISC CHECK VALVE INVESTMENT CASTING

SIZE:DN15~DN100

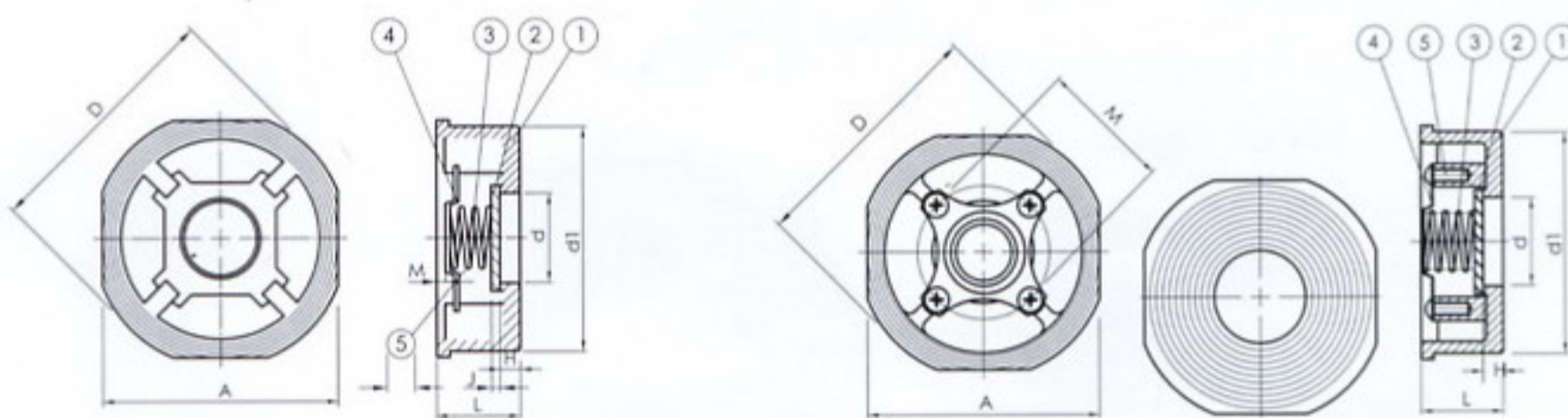

UNIT:MM

FEATURES: *body in ASTM A351-CF8M
 *Trim in AISI 316
 *DISC in ASTM-A351-CF8M

* MATERIAL LIST *

ITEM	PART	MATERIAL	Q.TY
1	BODY	ASTM A351 CF8M	1
2	DISC	ASTM A351 CF8M	1
3	SPRING	AISI 316	1
4	CAP	AISI 304	1
5	SCREW	AISI 304	4

DN	SIZE	d	d1	A	D	L	M	H	KGS WEIGHT
15	1/2	15	43	45	53	16.5	27.7	4.4	0.12
20	3/4	20	53	55	63	19.5	34.2	4.8	0.20
25	1"	25.4	63	65	73	22	39.4	5.4	0.30
32	1-1/4	30	75	78	84	28	43.7	6.0	0.40
40	1-1/2	38	86	88	94	32	54.0	6.6	0.60
50	2"	47	96	98	107	40	63.5	7.1	0.80
65	2-1/2	62.5	115	118	126	46	82.8	7.8	1.50
80	3"	77	130	134	144	50	98.8	8.4	1.90
100	4"	96	151	154	164	60	119.8	9.0	3.30